



Proudly Australian made & owned



LLF16.350 – SERIES 3

TECHNICAL SPECIFICATION & FEATURES

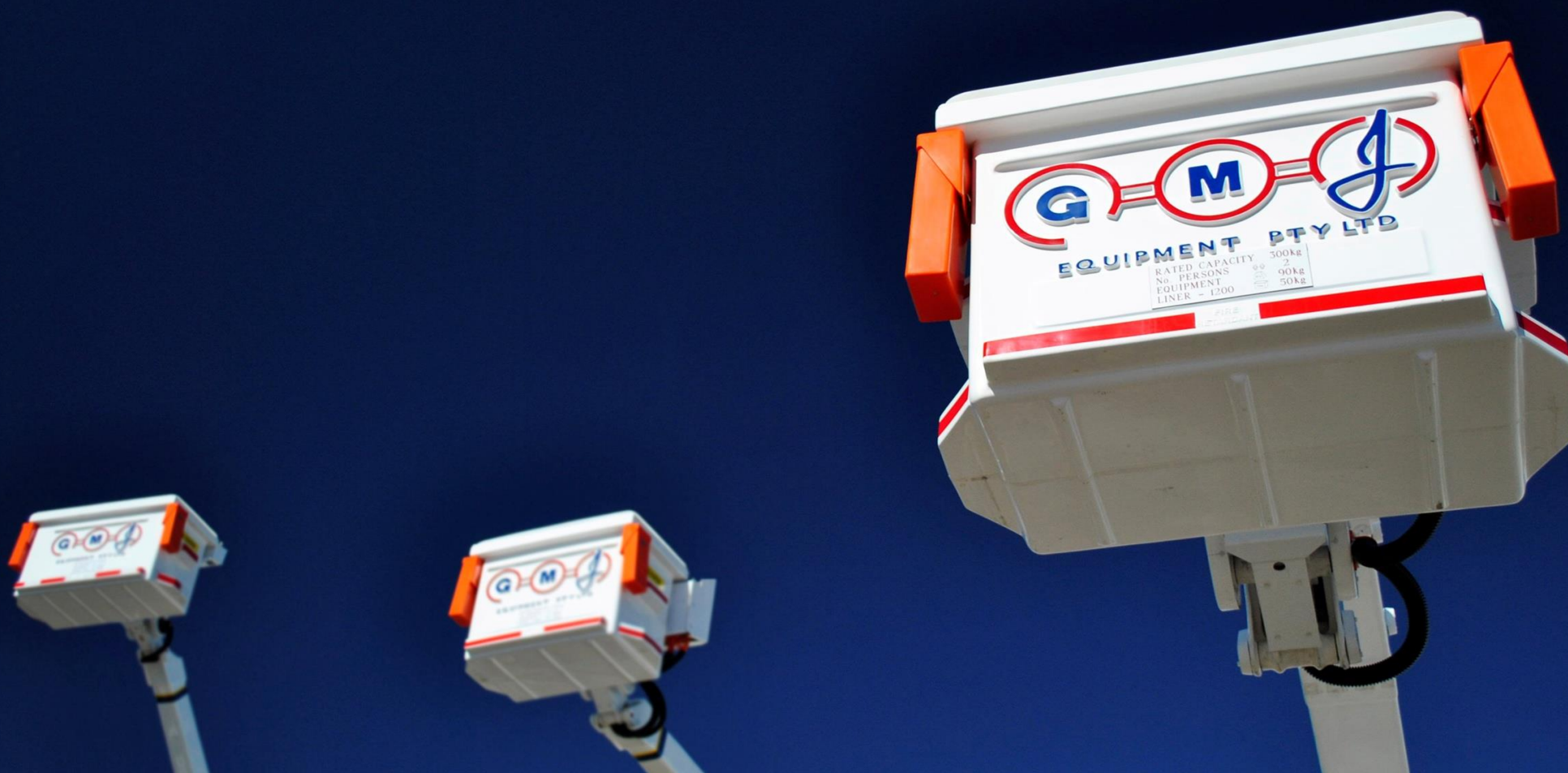

INTRODUCTION

The market leader in design and innovation, the LLF16.350 has a long standing reputation as the preferred MEWP in the electrical and tree service industry.

Designed to meet the superior Australian Standard for mobile elevated work platforms, this model has been under continuous refinement since it was first introduced to live line servicemen and arborists in 1999. Today it is one of GMJ's most established models, which in 2013 underwent additional improvements in design to meet the requests of operators and further enhance its capabilities.

A robust construction made to withstand the harsh Australian environment, the MEWP has been designed with serviceability in mind, sharing common components with other GMJ models to ensure spare parts are readily available.

The boom configuration has been tailored to maximise the working envelope, ensuring the operator can safely manoeuvre with ease. For protection against electrical hazards, the unit features a 33kV chassis insulator and a 132kV insert in the fly boom. Furthermore, the special coating applied to the fibreglass surfaces on the inside and outside of the components permits 33kV wet protection throughout the life cycle of the unit.



*For more information please visit www.gmj.com.au
Proudly designed and manufactured in Australia*

TECHNICAL SPECIFICATION & FEATURES

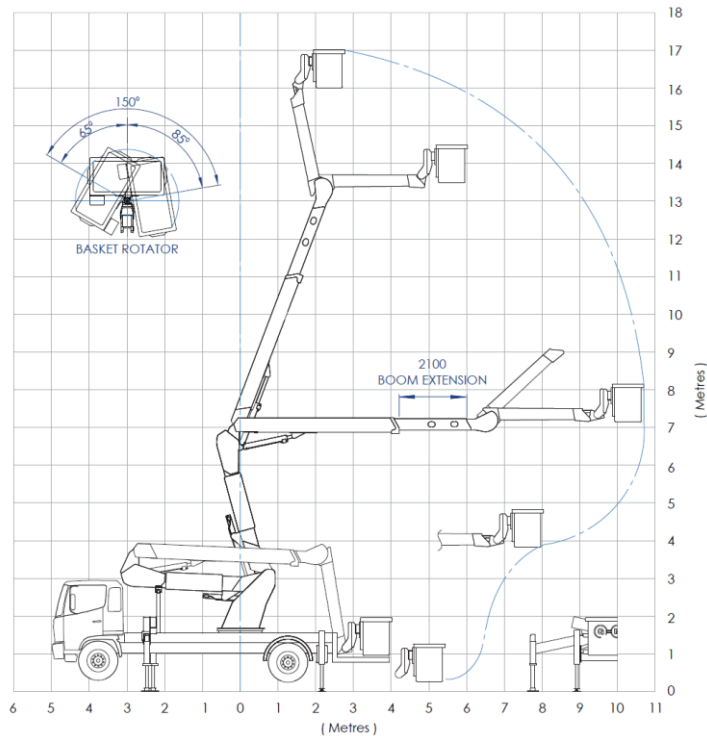

OPERATING SPECIFICATION

Model	LLF16-350 – Series 3	
Boom configuration type	Articulated / telescopic / fly	
Safe working load	350 kg	S
→ With basket rotator	350 kg	O
Basket construction	Fibreglass - Flame retardant to ASTM D635	
Working height	17.5 m	
Floor height	16.0 m	
Reach	11.0 m	
Relevant conformance standard	AS/NZS 1418.10:2011 – Mobile elevating work platforms	
Cab chassis requirement	4.8 m, 13,000 kg GVM	
	5.0 m – With basket rotator	

OPERATING SPECIFICATION CONT.

Mass of unit incl. tray body	6,700 kg – Approx	
Travel height	3.6 m – Approx	
→ INSULATION SPECIFICATION		
Chassis insulation rating	33 kV - Dry	S
	33 kV - Wet	O
Basket operator insulation rating	132 kV - Dry	S
	66 kV - Wet	O
Chassis insulation effective length	0.5 m	
Basket operator insulation effective length	2.0 m	
Low voltage insulation	All metallic portions about 4.5 m	
→ STABILISATION		
Front type	Hydraulic in/out – up/down	S
Rear type	Hydraulic up/down	S
Spring lockouts	No requirement for stabiliser legs to be deployed. Allows restricted slew from the stowed position	O
Automatic stabilisation	Automatic stow/engage & level at the touch of a button	O
Max. stabiliser spread	4.4 m	
Ground penetration	0.25 m	S
	0.40 m	O
	0.79 m – High-rise legs	O
Max. operating chassis slope	± 5°	
Max. stabiliser load	100 kN (10,000 kg) – Per pad	
Max. operating wind speed	12.5 m/s (45 km/h)	
Level indicators	3 off visible at stabiliser controls	S
→ BOOM PERFORMANCE		
Slew	Continuous 360°	
Lower boom	1.5° → 77°	
Upper boom	-11° → 75°	
Extension boom	2.1 m stroke	
Fly boom	-90° → 45°	

TECHNICAL SPECIFICATION & FEATURES

OPERATING SPECIFICATION CONT.

→ BOOM SPEEDS		
Slew ±360°	90 – 100 sec	
Lower boom – Raise/lower	35 – 45 sec	
Upper boom – Raise/lower	30 – 40 sec	
Extend – In/out	30 – 35 sec	
Fly boom – Raise/lower	20 – 25 sec	
→ SAFETY FEATURES		
Emergency stops	Emergency stops located at all control locations with indication light to illustrate when active	S
Over centre valves	O/centre valves fitted to all cylinders to prevent unintended movement in the unlikely event of hydraulic hose failure	S
Basket tilt	Basket tilt function to allow retrieval of injured personnel in the event of emergency use	S
Boom/Stabiliser interlock	Boom/stabiliser interlock to prevent the operation of the booms without the stabilisers safely engaged	S
Basket tie down interlock	Prevents the ability to pack up the stabiliser legs unless the basket is correctly tied down and the boom fully stowed	O
Back-up retrieval systems	Auxiliary manual controls located at the base	S
	Electro-hydraulic power pack	S
	Hand pump back-up for all booms and stabilisers	S
	Manual bleed down screws fitted to cylinders for manual retrieval	S
	Controlled decent devices fitted to the basket for each operator	S

FACTORY OPTIONS

FACTORY OPTIONS

→ MOTION CONTROLS		
Basket controls	Pilot pressure joystick	S
→ RADIO REMOTES (Single)		
	Autec	O

FACTORY OPTIONS CONT.

→ RADIO REMOTES (Dual)		
	Remote option also available in dual controls	O
Basket slew control	Inbuilt into remote & basket controls	O
Auxiliary base controls	Manual controls located at the pivot frame	S
	Spool positioning	O
Stabiliser controls	Location customer specific	S
Engine stop / start	Located at the basket & pivot frame (other locations avail.)	S
→ BASKET		
Basket construction	Fibreglass - Flame retardant to ASTM D635	S
	Non-slip grit type on internal/external access steps	S
Basket size (internal)	1.2 m (wide) x 0.7 m (long) x 1.0 m (high)	O
	1.35 (wide) x 0.65m (long) x 1.0m (high)	S
	1.5 m (wide) x 0.7 m (long) x 1.0 m (high)	O
Basket articulation	0° - Fixed	S
	150° - Helical rotary actuator	O
Basket liner	Flame retardant to ASTM D635 - Includes 2 internal access steps	O
Basket accessories	Lifting jib attachment - 150 kg SWL	O
	Ribbed vinyl basket cover	O
	Fibreglass removable tool tray	O
→ HYDRAULICS		
Hydraulic circuit	Closed centre	O
	Open centre	S
Hydraulic operating pressure	17 MPa	S
Hydraulic pilot pressure	3.5 MPa	S
PTO & Pump (Gear type)	Single displacement - Single (Closed centre)	S
	Single displacement - Tandem (Hydraulic tools)	O
Accumulator size (Closed centre)	37L	S
	50L	O
Hydraulic tank	140L - Capacity	S
	Sight glass with temperature gauge	S

FACTORY OPTIONS

FACTORY OPTIONS CONT.		
Pressure filter	10 micron	S
	3 micron	O
Return filter	10 micron	S
	Hydraulic oil related options	Water separator
	Oil cooler radiator with fan	O
	Temperature alarm	O
→ HYDRAULIC TOOLS		
Fitting type	Flush face	O
Intensifier	Located at the basket	O
Hydraulic tools pressure filter	10 micron (Standard on Open Centre circuit)	O
	3 micron	O
→ MOTION SYSTEMS		
Slew interlock	Single side operation with stabilisers retracted one side	O
Capacity interlock	Telescopic function restricted with stabiliser legs retracted and engaged	O
Traffic alarm	Warning buzzer when boom moves into traffic area	O
Out of level alarm	Buzzer active when chassis is greater than $\pm 5^\circ$ in either plane	O
Remote holder alarm	Buzzer active when radio remotes are not in holder when PTO is deactivated	O
→ BODY DETAIL		
Tray deck	Chequer plate - Steel	S
	Grid mesh - Steel	O
	Aluminium clip-lock	O
Drop tray	Chequer plate - Steel	S
	Aluminium chequer plate	O
Deck access	Fixed step	S
	Single fold up step	O
	Double fold up steps	O
	Fold up steps/ladder	X

FACTORY OPTIONS CONT.		
Mud guards	Steel	S
	Aluminium (Tray deck material dependant)	S
	Plastic bolt on	O
→ BODY LIGHTING		
Side clearance lights	LED type, 2 places	S
	LED type, 4 places	O
Tail lights	LED type	S
Number plate light	LED type	S
Revolving lights	LED beacon – Small / large	O
	Strobe	O
	LED flasher	O
	Customer specified	O
Work lights	LED spot light	O
	LED spread light	O
	LED spot/spread light combination	O
	Remote LED search light	O
Arrow light	LED arrow stick	O
	Single arrow – Swing over	O
	Double ended arrow	O
	Arrow board - Type A (LED)	O
	Arrow board - Type B (LED)	O
Locker lights	LED strip	O
Step lights	LED type - Fitted to all access step areas	O
→ INDICATION LIGHTING		
Exterior indication lighting	Boom not stowed	S
	Basket not tied down	O
	Stabiliser legs out	S

FACTORY OPTIONS

FACTORY OPTIONS CONT.		
	Stabiliser legs engaged	S
	Emergency stop active	S
	Boom stow light – Located on pivot frame	O
Cabin indication lighting	PTO Engaged	S
	PTO / truck hour meter	S
	Stabiliser not stowed	S
	Boom not stowed	O
	Step/vice not stowed	O
	Locker door open	O
	Pressure filter clogged (indicator on filter as standard)	O
	Return filter clogged	O
	Step lights on	O
→ POWER MANAGEMENT		
Dual batteries	Dual battery system	S
Battery management	Autonomous management system of the dual batteries, includes a start assist button in the cab for additional truck cranking power	O
Inverter	Customer specified	O
→ TOW BAR		
Type	Pintle	O
	Pintle & ball	O
Capacity	4,500 kg	O
	8,000 kg	O
Height	Customer specific	-
Plug	7 pin round - Small	O
	7 pin round - Large	O
→ PAINT & FINISHING		
	All components painted using 2 pack paint	S
Booms	Polished GRP - White	S
	Ultra-reflective red/white diamond tape safety stripes at knuckle	S
→ Steel work	White gloss	S

S STANDARD

O OPTION

X NOT APPLICABLE

FACTORY OPTIONS CONT.		
Tray body	Black gloss	S
→ Special	Special customer specific paint detail available	O
Hand rail	White gloss	S
	Yellow gloss	O
Access steps	White gloss	S
	Yellow gloss	O
Stabiliser legs	White gloss	S
	Ultra reflective red/white diamond tape safety stripe	S
Oil tank	White gloss	S
Boom rest	Black gloss	S
Basket	Ultra reflective red/white diamond tape safety stripe	S
Access steps	Non-slip grit strip on all steps	S

FACTORY FITTED ACCESSORIES

FACTORY FITTED ACCESSORIES		
→ LOCKERS		
Material	White powder coat 1.6 mm zinc anneal construction with field proven design to prevent water ingress	S
	3 mm aluminium, powder coated or raw	O
Internals	Fully customisable to customer specification	-
Features	Stainless steel lockable T-handles	S
	Stainless steel hinges	S
Options	Central locking	O
	Roller doors	O
	Hydraulic lift door	O
→ ALTERNATIVE STORAGE		
	Sign racks, ladder racks, rubbish bins, roof protector etc can be fitted as per customer specification	O

FACTORY FITTED ACCESSORIES

FACTORY FITTED ACCESSORIES CONT.

→ CAB CHASSIS ACCESSORIES

Operator terminal screen	In cab operator terminal screen:	
	▪ Control MEWP functions and accessories	
	▪ Live monitoring & data logging	
	▪ Diagnose & fault-finding tool	
	▪ Service information & reminders	
	▪ Plant certificates & manuals	
	▪ Trouble shooting menu	O
Tyre pressure management	A central tyre inflation system which allows the operator to control and monitor the air pressure in the tyres	O

→ MISCELLANEOUS ACCESSORIES

Stabiliser pads	Timber with rope grab handle	O
	Plastic moulded	O
	High impact polyethylene	O
Fire extinguisher	Wet - 9.0 kg	O
	Dry - 4.5 kg	O
	Dry - 9.0 kg	O
Water tank	15L including soap dispenser	O
	50L	O
Witches hat holder	On deck or under deck	O
Vice	100 mm fixed or slide out engineer's vice	O
Knap sack	16L with holder	O
	20L with holder	O
Cable drum carrier	Electroplated, 100 kg SWL	O
Recovery points	Rear recovery hooks	O
Spare wheel carrier	On deck or under deck	O
Wheel chocks	Rubber complete with grab handle and holder	O
Earth chain	16 mm chain link	O
Oil tank drain cock	Mounted to either side of the tray body	O
Spill kit	Oil & fuel spill kit supplied loose	O

Please contact GMJ Equipment regarding options not listed in this document

GMJ Equipment Pty Ltd
32 – 34 Quality drive, Dandenong South 3175
Victoria, Australia

P: (+613) 9706 4550
W: www.gmj.com.au
E: reception@gmj.com.au



Version: March 2021

All information in this document is correct at the time of publication, however variations may occur. GMJ Equipment, in so far as it is permitted by law to do so, shall not be liable in any way as a result of any reliance by any person on anything contained in this brochure. GMJ Equipment will provide upto-date information on model application, design features, prices and availability on request.